

# ***OWNER'S MANUAL***

## ***LIQUIDATOR MODEL 520***

- OPERATION
- MAINTENANCE
- TROUBLE SHOOTING
- REPAIR PARTS

*READ THESE  
INSTRUCTIONS  
BEFORE USING*



Order Parts Call 1-888-325-3252



201 COMMERCE DRIVE • MONTGOMERYVILLE, PA 18936  
215-393-4700 • 800-331-1423 • FAX 215-393-4800

## RECEIVING THE EQUIPMENT

- Inspect for obvious shipping damage or missing parts.
- Chassis – spreader rubber, manifolds, and wheel condition.
- Parts – handle hardware should be inside tank.
- Any damage or missing parts must be reported to Aztec Products within seven working days of receiving the equipment.

## LQ520 APPLICATIONS

Recommended surfaces:

- Vinyl and ceramic tile
- Sealed or finished concrete floors
- Wood, stone and terrazzo

## TRANSPORT OF EQUIPMENT TO SITES

- The LQ520 should be transported with the front swivel caster off the ground. This will prevent the spreader rubber from being damaged.
- Never lift tank by gripping the lid retainer ring.

## LQ520 SETUP

- Mount Handle — Insert studs into four (4) steel inserts on back of tank. Hand tighten only. Install nylon spacers on each stud, the steel washer on each stud. Install handle onto studs, then install other washers onto studs. Install side arm hanger bracket on lower right side stud. Install hex nut on each stud and tighten. **DO NOT OVER TIGHTEN OR DAMAGE MAY OCCUR.** Install levers on handle (blue tape designates location) and tighten.

## LQ520 OPERATION

- 1) Filling Tank — While filling with water, add specified amount of chemical as instructions direct. The tank capacity is 35 gallons. **DO NOT FILL BEYOND 1" BELOW LID OPENING.**
- 2) Coverage Width — The left valve control lever on the handle will dispense a 26" path in front of the machine. The right valve control lever will dispense an additional 26" path from the manifold on the right. The right arm will spring back to accommodate narrow areas.

- 3) Solution Coverage — The amount of solution dispensed will be determined by how much you squeeze the valve control levers and by how fast you walk. A normal walking speed should be sufficient for normal applications.
- 4) When completed, return right spreader manifold to the transport position. You can tip the unit back to lift the front spreader off the ground during transport.
- 5) If the solution is not being spread evenly across the floor, the tank may need to be refilled. See TROUBLE SHOOTING.

## MAINTENANCE & CLEANING UP

- 1) Drain the tank. Locate discharge valve at the front of tank. Position for proper draining. Lift "T" handle to regulate solution discharge. Tip machine forward for complete drainage. **Take care not to damage manifold or spreader material when draining.**

### ⚠ CAUTION!

Solution will discharge in a large steady stream with some pressure. Wear protective eye wear and avoid skin contact with all chemicals used in this tank.

- 2) Rinse tank and dispense clean water through manifolds.
- 3) To tilt machine, rest the unit on the handle. This will expose the undercarriage for cleaning.
- 4) Rinse wheels, chassis, and spreader rubber.
- 5) Drain excess water from unit by tipping forward and squeezing valve control levers.

## LQ520 STORAGE

- It is very important to drain all liquid from the unit if it is to be stored or transported in freezing conditions.

## TROUBLE SHOOTING

Problem: SOLUTION KEEPS RUNNING

Solution: Valve not closing properly.  
See VALVE SERVICE.

Problem: NOT SPREADING SOLUTION EVENLY

Solution: Check spreader material for tears. Replace if necessary. Check valve ports inside of tank for debris. Check manifolds for even flow with valves wide open. See MANIFOLD SERVICE.

Problem: LEAKS

Solution: See REPAIRING LEAKS section.

## VALVE SERVICE

- **Adjustment** — Turning the adjusting nut on the valve control lever located on the handle and locking with the jam nut will determine how much solution is dispensed on the floor. Normal operation will require about 1/8" of play in the valve control lever.
- **Re-Seating Valve** — Remove cable from valve control lever. Hold back conduit in one hand and the cable in the other. Pull the cable out as far as possible and let "SNAP" back. Repeat three times.
- **Debris in Valve** — Squeeze a valve control lever and force water with a hose through that valve port inside the tank.

## MANIFOLD SERVICE

- **Cleaning Manifold** — Remove both end caps and clean out with hose. Replace end caps.

## REPAIRING LEAKS

Isolate leak.

- **Fitting Leak** — Remove fitting, clean and smooth the surface and/or gasket. Apply silicon and reinstall.
- **Body Leak** — Contact Aztec Products, Inc., (215) 393-4700.

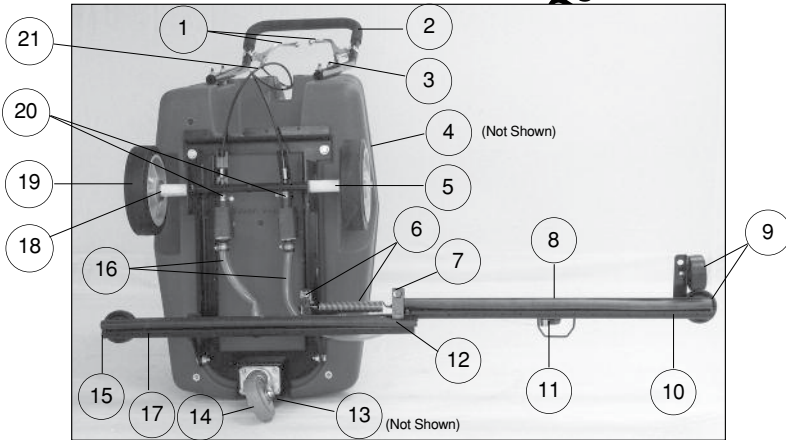

## REPAIR PARTS FOR LIQUIDATOR

| PART # | DESCRIPTION             | PART #          | QTY |
|--------|-------------------------|-----------------|-----|
| 1      | Valve Control Lever     | 314-J208PA-L7/8 | 2   |
| 2      | Handle                  | 285-74-9051     | 1   |
| 3      | Lock Nut                | 164-2202        | 1   |
| 4      | Lid and Ring            | 647-60032       | 1   |
| 5      | Wheel Spacer            | 216-PVC-3/4     | 1   |
| 6A     | Pivot Bolt Spring       | 173-MC080011SS  | 1   |
| 6B     | Arm Spring              | 173-MXQ11509MW  | 1   |
| 7      | Nylon Bushing           | 196-71200       | 1   |
| 8      | Right Manifold Assembly | 012-52-5211R    | 1   |
| 9      | Guide Wheels            | 156-PB-03041-08 | 2   |
| 10     | Spreader Rubber         | 175-03125N      | 5'  |
| 11     | Manifold Fitting        | 166-3EL1234G    | 1   |
| 12     | Front Manifold Assembly | 012-52-5210F    | 1   |
| 13     | 1 1/2 Gate Valve        | 150-17101       | 1   |
| 14     | 4" Swivel Caster        | 156-2-4056-445  | 1   |
| 15     | 1/2 MPT End Plug        | 166-3F126       | 1   |
| 16     | 3/4 Poly Tubing         | 216-0751        | 1   |
| 17     | Spreader Rubber         | 175-03125N      | 5'  |
| 18     | Axle Spacer Washer      | 164-76-100Z-WZ  | 1   |
| 19     | 8" Wheel                | 156-XA-08251-12 | 2   |
| 20     | Valve Assembly          | 012-52-5270     | 2   |
| 21     | Valve Cable             | 012-962C        | 2   |

Order Parts Call 1-800-421-7021

## LIMITED ONE YEAR WARRANTY

Aztec Products, Inc. warrants its products to be free from defects in material and workmanship for a period of one year from the date of sale.

Aztec Products, Inc. agrees, at its option, to repair or replace at its own expense any product or part(s) which examination proves to be defective in workmanship or materials provided that the purchaser notifies Aztec Products, Inc. directly, within the warranty period, and follows the Return Policy.

This warranty does not apply to or cover equipment damaged by misuse, abuse, neglect, accident, or any use not specified in the instruction manual, or any other circumstances that are out of the control of Aztec Products, Inc. or their authorized agents.

All repairs or changes must be made under the supervision or arrangement of Aztec Products, Inc. or their agents unless prior written consent has been issued. Any deviation from this arrangement shall make the owner of the equipment and/or party involved in those changes responsible for any and all damages resulting from such changes.

The foregoing is the entire and only Aztec Products, Inc. warranty which in no event covers incidental or consequential damages resulting from any such defective product or part(s). This warranty gives specific legal rights. Purchaser may have other rights which vary from state to state.

**This warranty is non-transferable.**

### AZTEC PRODUCTS, INC.

201 Commerce Drive • Montgomeryville, PA 18936 • 800-331-1423 • Fax 215-393-4800

## RETURN GOODS POLICY

As our customer, you are aware that the design and construction of this product are both innovative and unique. Since this is true, in order to troubleshoot our equipment, we rely heavily on returned defective or failed parts so that we can examine the causes of failure. While this may at first seem to be an inconvenience, ultimately you benefit from safer, better designed machine components. Please give us the opportunity to serve you better by following these RGA (Return Goods Authorization) rules.

1. We maintain the serial number, date of shipment or sale, and customer name on each piece of equipment sold. If you were the purchaser, please reference that information on your request for replacement or repair. If you purchased the equipment through a dealer, please include the company name, the date, and the serial number of the product.
2. Ask for an RGA number when you are ordering the replacement part. Return the failed part within 14 days, freight prepaid, exactly

as it was at the time of failure. Our inspection and evaluation will attempt to determine the probable cause of failure.

3. If our inspection reveals that the failed part was defective, we will credit your account for the entire amount of the part including your cost of return freight, but not packaging expense. When incomplete parts are returned for credit, their condition or state of incompletion will be assessed against the credit claim.
4. We will not accept freight collect returns or returns that do not indicate the RGA # on the packing list.

Your satisfaction is extremely important to us. We intend to be reasonable on any matter that is related to our warranty service or other wear-related problems which our customers feel need attention. Please help us to help you. Before assuming that a part is defective, check the repair manual to see if the problem might be something that you or one of your employees might be capable of correcting. If it is not, follow the above policy and depend on us to respond quickly and responsibly.

## PROTECT YOUR WARRANTY!

Read carefully, any questions regarding the care and safety of this unit, please

# CALL (800) 331-1423

201 COMMERCE DRIVE • MONTGOMERYVILLE, PA 18936

215-393-4700 • 800-331-1423 • FAX 215-393-4800